

# EZ TONE®

## INSTALLATION OF BRACKET FOR IN-SWING DOORS

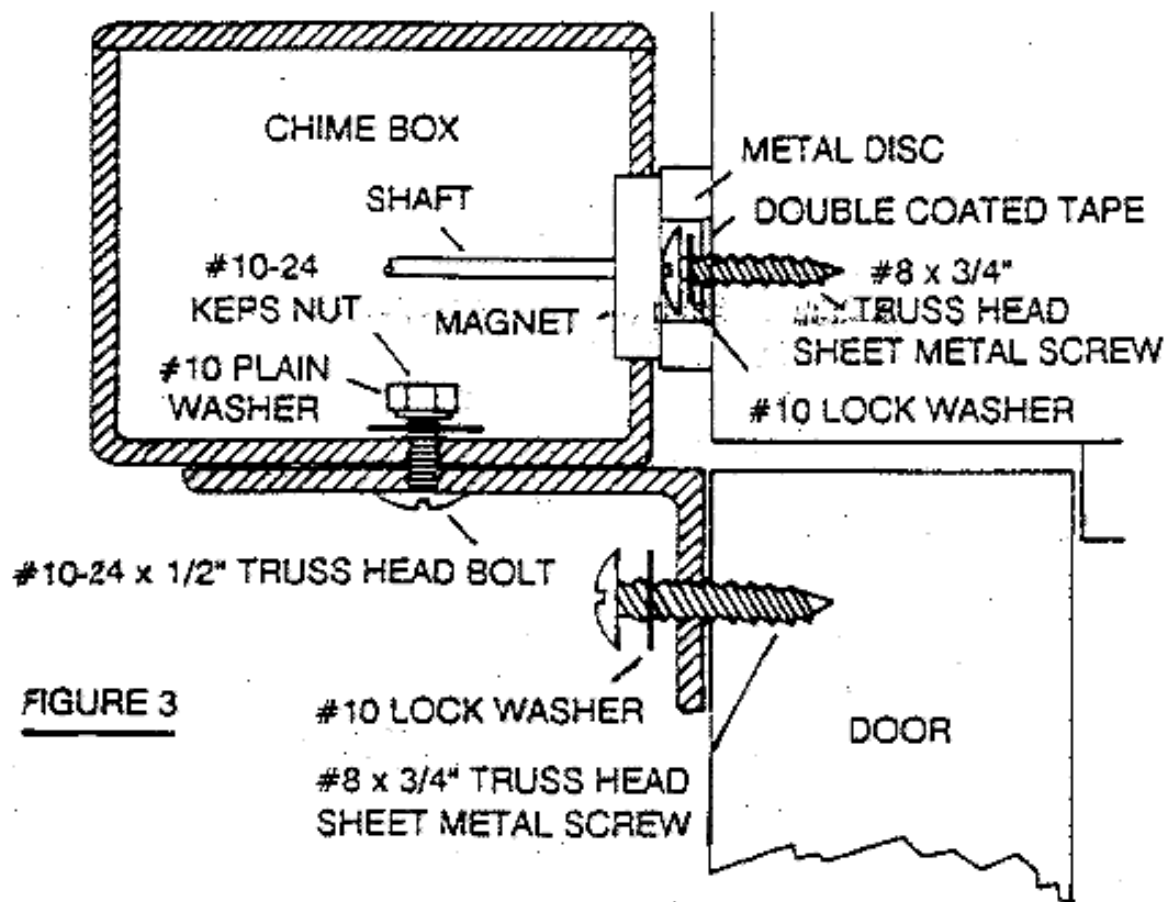

**FIGURE 3**

DRILL BIT INCLUDED: USE WITH ALL SCREWS (EXCEPT LID SCREWS)

**ABOVE ILLUSTRATION SHOWS TYPE OF INSTALLATION FOR IN-SWING DOORS**

1. Measure from frame side (where door opens) 2 inches in. along top edge of door and mark.

2. Place edge of bracket on mark and at same time, top of bracket must be flush with top of door. (See figure 3)
3. Use pencil and mark around mounting slots. Remove bracket.
4. Drill thru center of each slot mark.  By drilling thru center of slot marks, this will allow you to adjust bracket up or down to align with top edge of door.
5. Using 2-#8 X 3/4 truss head sheet metal screws and 2 lock washers, secure bracket to door, aligning top edge of bracket with top edge of door. (See figure 3)
6. Place and center metal disc on magnet cup. Tape side out. (DO NOT PEEL PAPER LINER).
7. Place chime box on top of bracket with magnet cup and metal disc facing door frame header. (See figure 3)
8. Align slots in chime box with slots in bracket. Secure together with 2-#10-24 truss head bolts, 2 plain washers and 2 kep nuts. (See figure 3)
9. Push chime box forward until metal disc comes in contact with header and tighten bolts.
10. Open door, peel paper liner off double-coated-tape on back of metal disc, exposing adhesive. Be sure area on frame where adhesive will stick is clean!
11. Check again that metal disc is centered on magnet cup. Close door, reach inside chime box and push shaft forward, pressing the metal disc against the frame header. This force will adhere metal disc to frame.
12. Drill center of hole in metal disc and secure with 1-#8 X 3/4 truss head sheet metal screw and lock washer. (See figure 3)
13. Be sure chime box is pushed forward so that magnetic cup is in contact with metal disc. Tighten nuts and bolts in mounting slots.
14. Place 2 feet on lid in slots in back of chime box. Push lid in position and secure with 2-#4 X 3/8 lid screws.
15. Your E-Z Tone Chime is now ready to operate.

# ***E-Z TONE***<sup>®</sup>

## INSTALLATION OF OUT-SWING DOORS

### ALUMINUM ENTRANCES WITH BLADE STOP

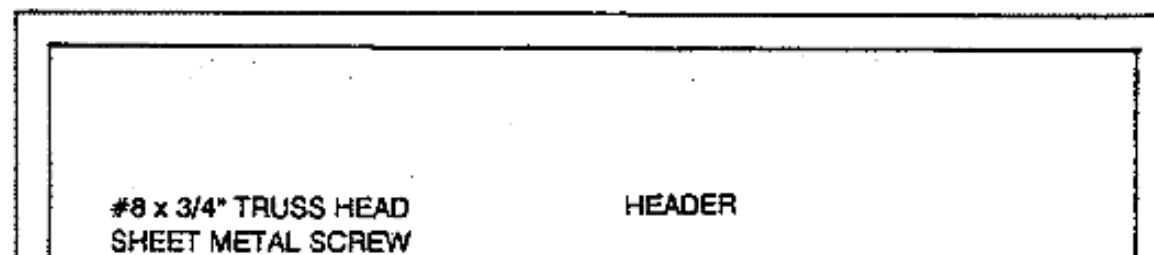
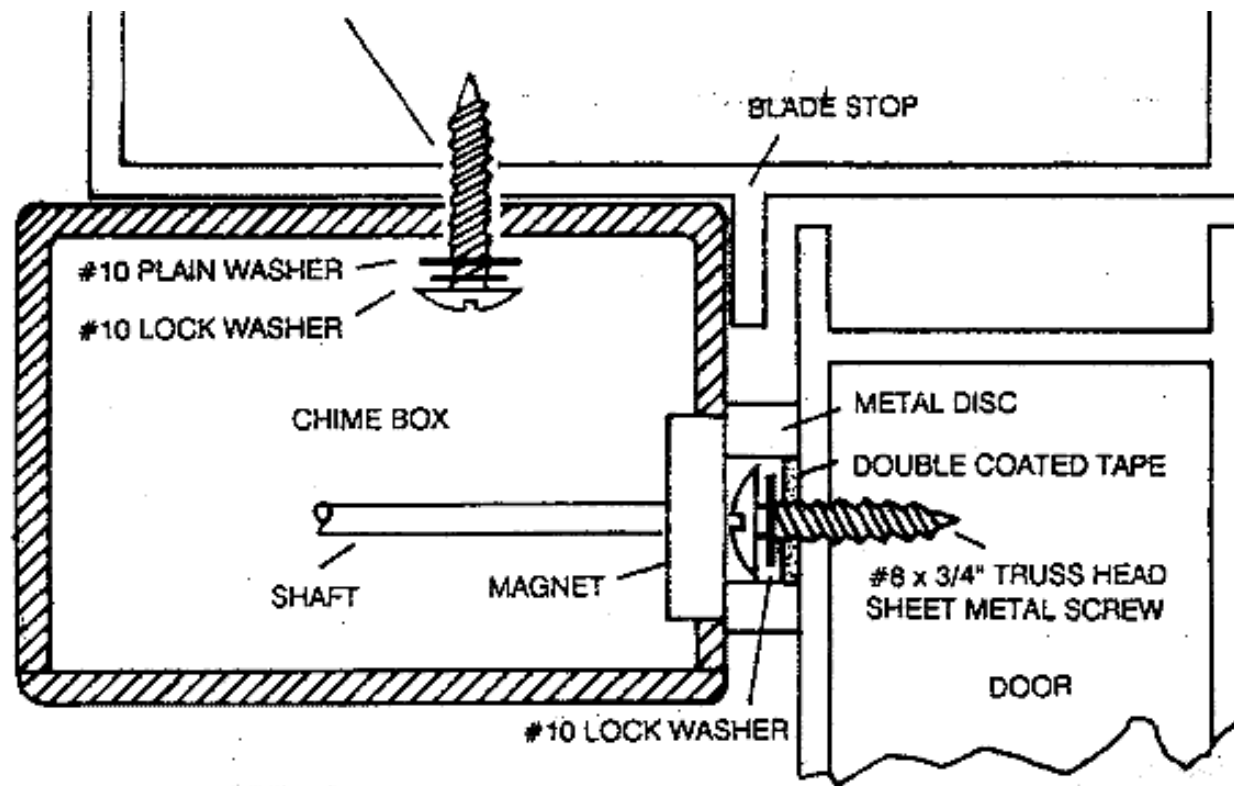

FIGURE 1.



DRILL BIT INCLUDED: USE WITH ALL SCREWS (EXCEPT LID SCREWS).

**Eliminate bracket, nut and bolt for this installation**

### ABOVE ILLUSTRATIONS SHOW TYPES OF INSTALLATION OUT-SWING DOORS

1. Measure from frame side (where door opens) 2 inches in along header and mark.
2. Place and center metal disc on magnet cup. Tape side out. (DO NOT REMOVE PAPER LINER)
3. Place chime box edge on header at 2 inch mark, with magnet cup and metal disc facing door. (See figure. 1)
4. Push chime box forward until metal disc comes in contact with door.
5. Use a pencil and mark around mounting slots. Remove chime box.
6. Drill thru center of each slot mark. -- By drilling thru center of slot marks, this will allow you to adjust chime box forward or backward after mounting.
7. Mount chime box with 2-#8 X 3/4 truss head sheet metal screws, 2 plain washers and 2 lock washers.  
(See figure. 1)

8. Open door, peel paper liner off double coated tape on back of metal disc, exposing adhesive. Be sure the area on door where adhesive will stick is clean!
9. Check again that metal disc is centered on magnet cup. Close door, reach inside chime box and push shaft forward, pressing the metal disc against the door. This force will adhere metal disc to door.
10. Drill center of hole in metal disc and secure with 1-#8 X 3/4 truss head sheet metal screw and lock washer. (See figure. 1)
11. Be sure chime box is pushed forward so that magnetic cup is in contact with metal disc. Chime box must be in a straight line with header. Tighten screws in mounting slots of chime box.
12. Place 2 feet on lid in slots in back of chime box. Push lid in position and secure with 2-#4 X 3/8 lid screws.
13. Your E-Z Tone Chime is now ready to operate.

© Copyright - 2005 - 2007  
Lord Henry Enterprises, Inc.  
3524 Central Pike, Suite 304  
Hermitage, TN 37076

Unauthorized use or reproduction is strictly prohibited.



Want a Special Buy? Look at [www.SpecialBuys.Com](http://www.SpecialBuys.Com)